

Timer - Multifunction

G2ZMF11

GAMMA series

16 functions

16 time ranges

Connection of remote potentiometer possible

Supply voltage selectable via power modules

2 change-over contacts

Width 22.5mm

Industrial design



Technical data

1. Functions

1 delayed contact (terminals 15-16-18) and

1 instantaneous contact (terminals 25-26-28)

E11	ON delay
R11	OFF delay with control contact
Es11	ON delay with control contact
Wu11	Single shot leading edge voltage controlled
Ws11	Single shot leading edge with control contact
Wa11	Single shot trailing edge with control contact
Bi11	Flasher pulse first
Bp11	Flasher pause first

2 delayed contacts

E20	ON delay
R20	OFF delay with control contact
Es20	ON delay with control contact
Wu20	Single shot leading edge voltage controlled
Ws20	Single shot leading edge with control contact
Wa20	Single shot trailing edge with control contact
Bi20	Flasher pulse first
Bp20	Flasher pause first

2. Time ranges

Time range	Adjustment range
1s	50ms 1s
3s	150ms 3s
10s	500ms 10s
30s	1500ms 30s
1min	3s 1min
3min	9s 3min
10min	30s 10min
30min	90s 30min
1h	3min 1h
3h	9min 3h
10h	30min 10h
30h	90min 30h
1d	72min 1d
3d	216min 3d
10d	12h 10d
30d	36h 30d

3. Indicators

Green LED ON: indication of supply voltage

Green LED flashes: indication of time period

Yellow LED ON/OFF: indication of relay output

4. Mechanical design

Self-extinguishing plastic housing, IP rating IP40

Mounted on DIN-Rail TS 35 according to EN 60715

Mounting position: any. Shockproof terminal connection according to VBG 4 (PZ1 required), IP rating IP20

Tightening torque: max. 1Nm

Terminal capacity:

- 1 x 0.5 to 2.5mm² with/without multicore cable end
- 1 x 4mm² without multicore cable end
- 2 x 0.5 to 1.5mm² with/without multicore cable end
- 2 x 2.5mm² flexible without multicore cable end

5. Input circuit

Supply voltage:

12 to 400V a.c.

terminals A1-A2 (galvanically separated) selectable via power modules TR2

according to specification of power module

according to specification of power module

Tolerance:

Rated frequency:

Rated consumption:

Duration of operation:

Reset time:

Residual ripple for d.c.:

Drop-out voltage:

Overvoltage category:

Rated surge voltage:

6. Output circuit

2 potential free change-over contacts

Rated voltage:

Switching capacity:

If the distance between the devices is less than 5mm.

Switching capacity:

If the distance between the devices is greater than 5mm.

Fusing:

Mechanical life:

Electrical Life:

Switching frequency:

max. 60/min at 100VA resistive load

max. 6/min at 1000VA resistive load

(in accordance with IEC 60947-5-1)

Overvoltage category:

Rated surge voltage:

4kV

7. Control contact

Activation:

Potential free:

Loadable:

Control voltage:

Short circuit current:

Line length:

Control pulse length:

bridge Y1-Y2

yes, basic isolation against input and output circuit

no

max. 5V

max. 1mA

max. 10m

min. 50ms

8. Remote potentiometer (not included)

The internal potentiometer is de-activated when a remote potentiometer is connected !!!

Connections:

1M Ω potentiometer (type RONDO R2),

terminals Z1-Y2

Line type:

Control voltage:

Short circuit current:

Line length:

twisted pair

max. 5V

max. 5 μ A

max. 5m

Technical data

9. Accuracy

Base accuracy: $\pm 1\%$ (of maximum scale value) using 1M Ω remote potentiometer
 Frequency response: -
 Adjustment accuracy: $\leq 5\%$ (of maximum scale value) using 1M Ω remote potentiometer
 Repetition accuracy: $< 0.5\%$ or $\pm 5\text{ms}$
 Voltage influence: -
 Temperature influence: $\leq 0.01\% / ^\circ\text{C}$

10. Ambient conditions

Ambient temperature: -25 to +55 $^\circ\text{C}$ (in accordance with IEC 60068-1)
 -25 to +40 $^\circ\text{C}$ (in accordance with UL 508)
 Storage temperature: -25 to +70 $^\circ\text{C}$
 Transport temperature: -25 to +70 $^\circ\text{C}$
 Relative humidity: 15% to 85%
 (in accordance with IEC 60721-3-3 class 3K3)
 Pollution degree: 3 (according to IEC 60664-1)
 Vibration resistance: 10 to 55Hz 0.35mm
 (in accordance with IEC 60068-2-6)
 Shock resistance: 15g 11ms (according to IEC 60068-2-27)

Functions

The internal potentiometer is de-activated when a remote-potentiometer is connected! The function has to be set before connecting the relay to the supply voltage.

ON delay (E11)

When the supply voltage U is applied, the instantaneous contact switches into on-position and the set interval t begins (green LED flashes). After the interval t has expired (green LED illuminated) the delayed contact switches into on-position (yellow LED illuminated). This status remains until the supply voltage is interrupted. If the supply voltage is interrupted before the expiry of the interval t, the interval already expired is erased and is restarted when the supply voltage is next applied.

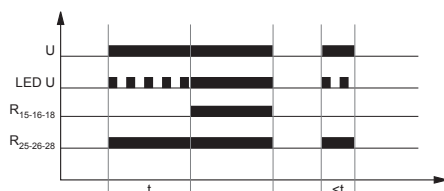

OFF delay with control contact (R11)

The supply voltage U must be constantly applied to the device (green LED illuminated). When the control contact Y1-Y2 is closed, both contacts switch into on-position (yellow LED illuminated). If the control contact is opened, the instantaneous contact switches into off-position and the set interval t begins (green LED flashes). After the interval t has expired (green LED illuminated) the delayed contact switches into off-position (yellow LED not illuminated). If the control contact is closed again before the interval t has expired, the interval already expired is erased and is restarted with the next cycle.

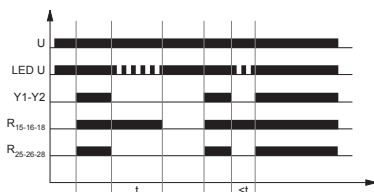

ON delay with control contact (Es11)

The supply voltage U must be constantly applied to the device (green LED illuminated). When the control contact Y1-Y2 is closed, the instantaneous contact switches into on-position and the set interval t begins (green LED flashes). After the interval t has expired (green LED illuminated) the delayed contact switches into on-position (yellow LED illuminated). This status remains until the control contact is opened again.

If the control contact is opened before the interval t has expired, the interval already expired is erased and is restarted with the next cycle.



Single shot leading edge voltage controlled (Wu11)

When the supply voltage U is applied, both contacts switch into on-position (yellow LED illuminated) and the set interval t begins (green LED flashes). After the interval t has expired (green LED illuminated) the delayed contact switches into off-position (yellow LED not illuminated). This status remains until the supply voltage is interrupted. If the supply voltage is interrupted before the interval t has expired, the both contacts switch into off-position. The interval already expired is erased and is restarted when the supply voltage is next applied.

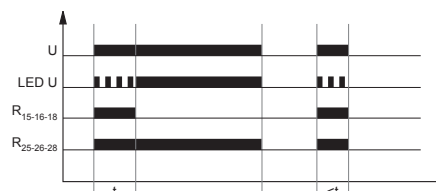

Single shot leading edge with control contact (Ws11)

The supply voltage U must be constantly applied to the device (green LED illuminated). When the control contact Y1-Y2 is closed, both contacts switch into on-position (yellow LED illuminated) and the set interval t begins (green LED flashes). After the interval t has expired (green LED illuminated) the delayed contact switches into off-position (yellow LED not illuminated). The instantaneous contact remains in on-position, until the control contact is opened again. During the interval, the control contact (and the instantaneous contact) can be operated any number of times. A further cycle can only be started when the cycle run has been completed.

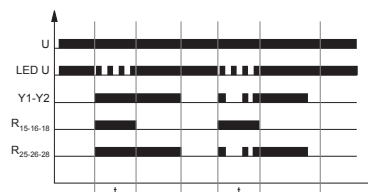

Functions

Single shot trailing edge with control contact (Wa11)

The supply voltage U must be constantly applied to the device (green LED illuminated). When the control contact Y1-Y2 is closed the instantaneous contact switches into on-position. When the control contact is opened, the instantaneous contact switches into off-position, the delayed contact switches into on-position (yellow LED illuminated) and the set interval t begins (green LED flashes). After the interval t has expired (green LED illuminated), the delayed contact switches into off-position (yellow LED not illuminated). During the interval, the control contact (and the instantaneous contact) can be operated any number of times. A further cycle can only be started when the cycle run has been completed.

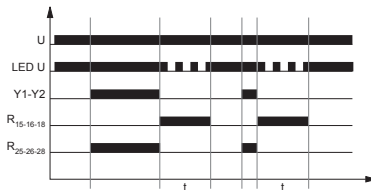

Flasher pulse first (Bi11)

When the supply voltage U is applied, the instantaneous contact and the delayed contact switch into on-position (yellow LED illuminated) and the set interval t begins (green LED flashes). After the interval t has expired, the delayed contact switches into off-position (yellow LED not illuminated) and the set interval t begins again. The delayed contact is triggered at a ratio of 1:1 until the supply voltage is interrupted.

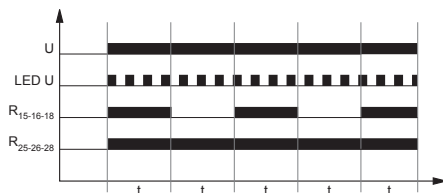

Flasher pause first (Bp11)

When the supply voltage U is applied, the instantaneous contact switches into on-position and the set interval t begins (green LED flashes). After the interval t has expired, the delayed contact switches into on-position (yellow LED illuminated) and the set interval t begins again. After the interval t has expired, the delayed contact switches into off-position (yellow LED not illuminated). The delayed contact is triggered at a ratio of 1:1 until the supply voltage is interrupted.

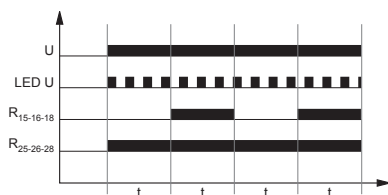

ON delay (E20)

When the supply voltage U is applied, the set interval t begins (green LED flashes). After the interval t has expired (green LED illuminated) the output relay R switches into on-position (yellow LED illuminated). This status remains until the supply voltage is interrupted. If the supply voltage is interrupted before the expiry of the interval t, the interval already expired is erased and is restarted when the supply voltage is next applied.

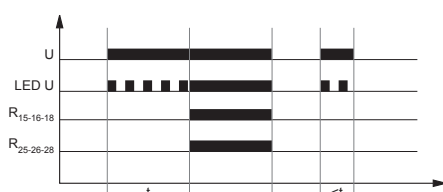

OFF delay with control contact (R20)

The supply voltage U must be constantly applied to the device (green LED illuminated). When the control contact Y1-Y2 is closed, the output relay R switches into on-position (yellow LED illuminated). If the control contact is opened, the set interval t begins (green LED flashes). After the interval t has expired (green LED illuminated) the output relay switches into off-position (yellow LED not illuminated). If the control contact is closed again before the interval t has expired, the interval already expired is erased and is restarted with the next cycle.

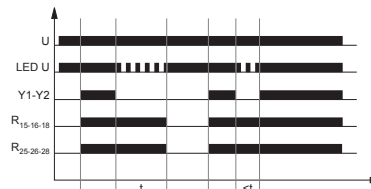

ON delay with control contact (Es20)

The supply voltage U must be constantly applied to the device (green LED illuminated). When the control contact Y1-Y2 is closed, the set interval t begins (green LED flashes). After the interval t has expired (green LED illuminated) the output relay R switches into on-position (yellow LED illuminated). This status remains until the control contact is opened again. If the control contact is opened before the interval t has expired, the interval already expired is erased and is restarted with the next cycle.

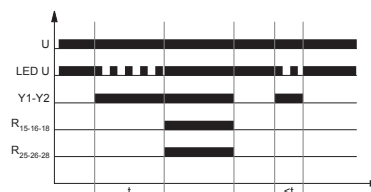

Single shot leading edge voltage controlled (Wu20)

When the supply voltage U is applied, the output relay R switches into on-position (yellow LED illuminated) and the set interval t begins (green LED flashes). After the interval t has expired (green LED illuminated) the output relay switches into off-position (yellow LED not illuminated). This status remains until the supply voltage is interrupted. If the supply voltage is interrupted before the interval t has expired, the output relay switches into off-position. The interval already expired is erased and is restarted when the supply voltage is next applied.

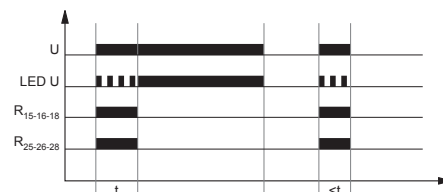

Single shot leading edge with control contact (Ws20)

The supply voltage U must be constantly applied to the device (green LED illuminated). When the control contact Y1-Y2 is closed, the output relay R switches into on-position (yellow LED illuminated) and the set interval t begins (green LED flashes). After the interval t has expired (green LED illuminated) the output relay switches into off-position (yellow LED not illuminated). During the interval, the control contact can be operated any number of times. A further cycle can only be started when the cycle run has been completed.

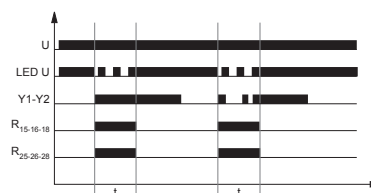

Functions

Single shot trailing edge with control contact (Wa20)

The supply voltage U must be constantly applied to the device (green LED illuminated). Closing the control contact Y1-Y2 has no influence on the condition of the output relay R. When the control contact is opened, the output relay switches into on-position (yellow LED illuminated) and the set interval t begins (green LED flashes). After the interval t has expired (green LED illuminated), the output relay switches into off-position (yellow LED not illuminated). During the interval, the control contact can be operated any number of times. A further cycle can only be started when the cycle run has been completed.

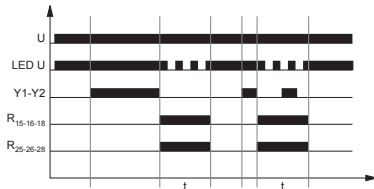

Flasher pulse first (Bi20)

When the supply voltage U is applied, the output relay R switches into on-position (yellow LED illuminated) and the set interval t begins (green LED flashes). After the interval t has expired, the output relay switches into off-position (yellow LED not illuminated) and the set interval t begins again. The output relay is triggered at a ratio of 1:1 until the supply voltage is interrupted.

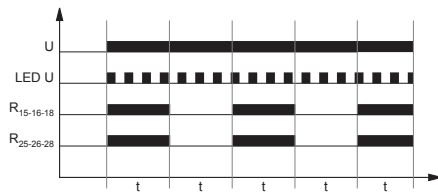

Flasher pause first (Bp20)

When the supply voltage U is applied, the set interval t begins (green LED flashes). After the interval t has expired, the output relay R switches into on-position (yellow LED illuminated) and the set interval t begins again. After the interval t has expired, the output relay switches into off-position (yellow LED not illuminated). The output relay is triggered at a ratio of 1:1 until the supply voltage is interrupted.

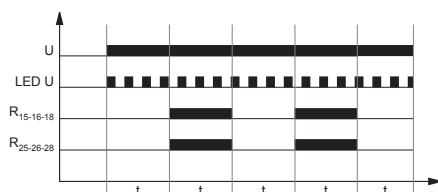

Dimensions

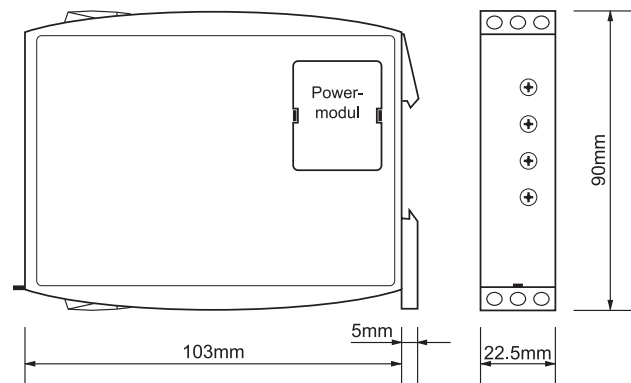

Connections

