

SIM200™

Active Insulation Monitoring Device

The SIM200 Insulation Monitoring Device (IMD) is designed for continuous active monitoring of unearthed (Isolated Terra) DC systems including charging stations, e-mobility applications, and any other system with a nominal operation above 60 VDC.

The SIM200 is UL2231 recognized to ensure safety at the highest standards and responds to electric hazards quickly and reliably with a patented signal injection algorithm and processing for continuous “Always On” monitoring of insulation.

Additionally, this IMD provides robust self-diagnosis of its monitoring functions, modular CAN 2.0B interface for detailed system information, warning alarm with configurable level, fault alarm at 100 Ω/V and configurable CAN ID for flexibility.

Features

Safety

- Continuous, “Always On” system monitoring of insulation
- Dedicated fault state output via PWM
- Stored capacitive energy monitoring
- Digital out to indicate internal IMD error

Usability

- Warning alarm with configurable level
- Fault alarm at 100 Ω/V (Configurable fault threshold available; See Ordering Options)
- Configurable CAN ID

Performance

- Modular CAN 2.0B interface
- Robust self-diagnosis of monitoring functions

Benefits

- UL 2231-2 recognized
- Tested to IEC/EN 61557-8 and IEC/EN 61326-2-4
- Suitable for any application from 60 V - 1500 V
- Patented signal injection algorithm for continuous, “Always On” system monitoring

Applications



Charging Station



E-Mobility

SIM200™

Parameter	Min	Typical	Max	Unit	Conditions / Comments
Power and General Characteristics					
Operational Supply voltage	9	12-24	30	V	
Operational supply current	-	60 28	-	mA	12 V supply 24 V supply
Operating temperature range	-40	-	+85	°C	
Input Impedance Rin	-	2720 2720 1000 272	-	kΩ	xNx xKx xPx xQx Input impedance varies based on the device voltage configuration (hardware configured). The input impedance of the monitor is the parallel impedance imposed by the SIM200 between each rail and the chassis. See "Ordering Options" for more information.
Isolation Monitoring Function					
Time to initial isolation estimate	-	4.5	5.5	Seconds	
Response time to warning condition	4.3	-	5	Seconds	Applies to the detection of warning (500 Ω/V) condition from a stable initial state under typical operating conditions.
Response time to fault condition	-	5.3	5.8	Seconds	Applies to the detection of fault (100 Ω/V) condition from a stable initial state under typical operating conditions.
Response time to short condition	-	-	6.5	Seconds	Time needed to confirm short condition, for equivalent resistances for each variant see "Reporting of Short Condition".
Application Voltage Range (Vb)	1000 600 300 60	1363 1000 510 140	1568 1150 582 161	V	xNx xKx xPx xQx "Typical" value is the max nominal system voltage to meet IEC/EN 61557-8 and allow for operation at 115% of nominal.
Total Y-capacitance	0.2 0.2 0.9 2	1.2 1.2 4.2 6.2	4.2 4.2 14.2 14.2	μF	xNx xKx xPx xQx See "Y-Capacitors" section for more information. If higher Y-capacitance is desired, contact Sensata for further discussion.
Isolation Resistance Measurements					
Reporting range	0	-	2720 2720 1000 272	kΩ	xNx xKx xPx xQx The SIM200 provides the total resistance value for each HV rail, including that imposed by the SIM200 module itself, which is the upper bound for system insulation.
Measurement resolution	-	1	-	kΩ	
Measurement accuracy	-	±5 ±5 ±5 ±3	±15 ±15 ±15 ±5	%	xNx xKx xPx xQx Listed accuracies are achieved when system isolation is stable and under typical operating conditions.
Measurement update period	-	250	-	ms	
Reporting of short condition	-	8 8 1.5 0.4	-	kΩ	xNx xKx xPx xQx Short condition will be reported when the isolation resistance of one of the High Voltage rail falls below the listed value.
Reporting of short condition – low voltage mode	-	16 16 3 0.8	-	kΩ	xNx xKx xPx xQx Low voltage mode when battery voltage < 15 V.
Total Capacitance Measurement					
Reporting range	0.2	1	-	μF	The total capacitance of the system is defined as the sum of all Y-capacitance in the system.
Measurement resolution	-	1	-	nF	
Measurement accuracy	-	±10	-	%	Typical accuracy is achieved when the system time constant is between 0.5 s and 1.5 s and under typical operating conditions, and capacitive measurement uncertainty is reported <10% confidence interval.
Measurement update period	-	250	-	ms	

SIM200™

Parameter	Min	Typical	Max	Unit	Conditions / Comments
Noise Immunity of Measurements					
Common mode voltage on the battery terminals	20	-	-	V _{PK-PK}	No observable effect on isolation resistance value. Measured with square, ramp, and sine wave test signals from 1 kHz to 100 kHz. Common mode noise below 1 kHz expected to interfere with isolation resistance measurement.
Differential mode voltage on the battery terminals (battery voltage variations)	-	100	-	V _{PK-PK}	No observable effect on isolation resistance value. Tested with battery-voltage driving profile that has multiple instantaneous voltage changes up to ±100 V and overall slow battery voltage fluctuation from 910 V to 480 V.

Voltage Measurements

Measurement range	±1627 ±1168 ±599 ±164	±1652 ±1186 ±608 ±167	-	V	xNx xKx xPx xQx	Applies to HV rail measurements with respect to chassis.
Offset error	-100	±50	+100	mV		Over operating temperature range.
Gain error	-2	±0.5	+2	%		Over operating temperature range.
Measurement resolution (compact reporting)	-	1	-	V		
Measurement resolution (high-resolution reporting)	-	100	-	µV		
Measurement update period	-	10	-	ms		

Temperature Measurement

Absolute measurement error	-5	±0.5	+5	°C		Over operating temperature range.
Measurement resolution	-	10	-	m°C		
Measurement update period	-	250	-	ms		

Communication and Connectors

Parameter	Spec	Speed	Termination
CAN Communication	2.0B	500 or 250 kbit/s	120 Ω termination resistor (optional).

Connectors

Parameter	Manufacturer	Position	Part Number	Description
COM & power on board	Molex	6	705510040	P1: 6 pos. right angle single header, shrouded connector (2.54 mm) through hole tin.
COM & power mating connector	Molex	6	50579406	Use appropriate crimp contacts (available for AWG 22, 24 and 26).
Voltage sensing on board	Molex	2	705510036	J1, J3, J4: 2 pos. right angle single header, shrouded connector (2.54mm) through hole tin.
Voltage sensing mating connector	Molex	2	50579402	Use appropriate crimp contacts (available for AWG 22, 24 and 26).

SIM200™

Resistance Measurement Accuracy – xNx and xKx Variants

Isolation excluding input impedance of IMD.

Accuracies for operation under nominal conditions, battery voltage ≥ 15 V.

Accuracy under 0 V operation $\leq 15\%$ error for fault detection, compliant with IEC/EN 61557-8.

xNx and xKx Absolute Error - Asymmetrical

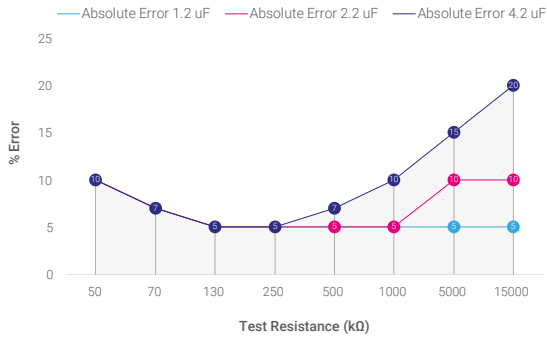

Non test side resistance leakage = 15 MΩ
 ± 10 kΩ for resistances < 50 kΩ

xNx and xKx Absolute Error - Symmetrical

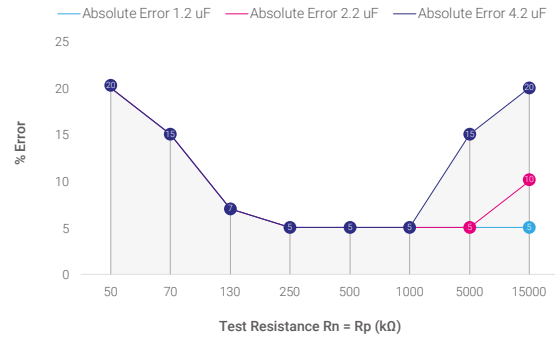

± 15 kΩ for resistances < 50 kΩ

Resistance Measurement Accuracy - xPx

Isolation excluding input impedance of IMD.

Accuracies for operation under nominal conditions, battery voltage ≥ 15 V.

Accuracy under 0 V operation $\leq 15\%$ error for fault detection, compliant with IEC/EN 61557-8.

xPx Absolute Error - Asymmetrical

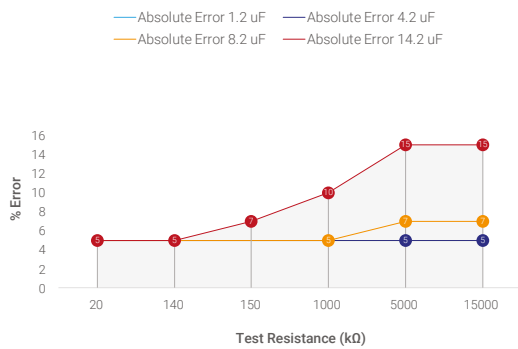

Non test side resistance leakage = 15 MΩ
 ± 3 kΩ for resistances < 20 kΩ

xPx Absolute Error - Symmetrical

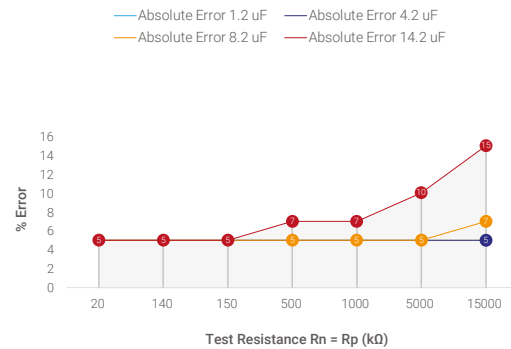

± 3 kΩ for resistances < 20 kΩ

SIM200™

Resistance Measurement Accuracy - xQx

Isolation excluding input impedance of IMD.

Accuracies for operation under nominal conditions, battery voltage ≥ 15 V.

Accuracy under 0 V operation $\leq 15\%$ error for fault detection, compliant with IEC/EN 61557-8.

xQx Absolute Error - Asymmetrical

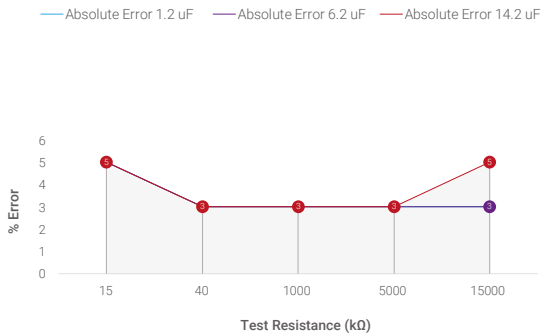

Non test side resistance leakage = 15 MΩ
 ± 1.5 kΩ for resistances <15 kΩ

xQx Absolute Error - Symmetrical

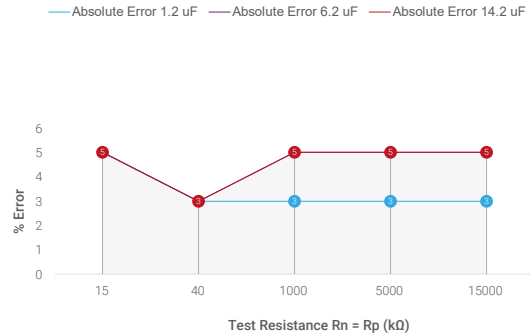

± 1.5 kΩ for resistances <15 kΩ

SIM200 Reported Uncertainties

Along with the isolation resistance and system Y-capacitance estimate, the SIM200 reports an “uncertainty” value. The uncertainty measure provided should be understood as a measure of the suitability of the model (or lack of suitability), rather than as a measure of accuracy.

In application, it is suggested that this uncertainty may be used in the following ways:

Estimates with high levels of uncertainty should be ignored. A recommended threshold is $\leq 10\%$ uncertainty for the estimate of interest. This is already handled on the SIM200 by the “High Uncertainty” status bit, which is set to 1 when one or more isolation estimate uncertainty is above 10% (see CAN protocol for detail).

For most applications monitoring the resistive leakage path, no direct monitoring of the uncertainties is needed – only applicable monitoring of the status byte.

For applications that require more certainty in the isolation estimate, an uncertainty threshold of less than 10% can be used.

For sudden changes in the isolation parameters the IMD is monitoring, the uncertainty on the isolation parameters will spike until the change has settled and the IMD can resolve the parameters. A spike in the uncertainties (in a properly installed SIM200) indicates a sudden change in the isolation parameters or measurement circuit.

CAN Interface

SIM200 module utilizes a simple CAN “polling” interface in which the system controller requests desired information according to a library of “Operation Codes” or “Op Codes”.

The CAN interface can be utilized by the system to obtain detailed system status information, as well as detailed diagnostic information.

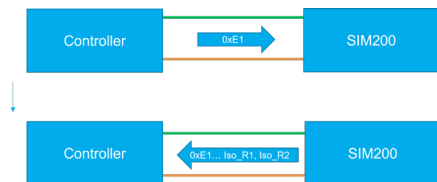

Example Op Codes

Description	Op_Code
Get isolation state	0xE0
Get isolation resistances	0xE1
Get system Y-capacitances	0xE2
Get HV rail measurements	0xE3
Get battery voltage	0xE4
Get error flags	0xE5
Get dynamic electrical isolation	0xE6
Get dynamic capacitive energy	0xE7

SIM200™

Y-Capacitors

Y-capacitance in un-earthed DC systems

The Y-capacitances in an IT DC system are the total capacitances that exist between the high voltage conductors (+/-) and the chassis (or protected earth) of that system. The values in each system are the total of the parasitic capacitances associated with the particular system design, including loads, conductor routing, etc, as well as the physical Y-capacitor components designed into such systems for Electromagnetic Interference (EMI) and converter noise suppression.

Presence of Y-capacitors

The SIM200 relies on the presence of the ubiquitous Y-capacitors in the application system to perform its safety function of self-diagnosing its proper connections to the high voltage system. Absence of Y-capacitors with the minimum total value listed in the datasheet will generate a connection diagnostic.

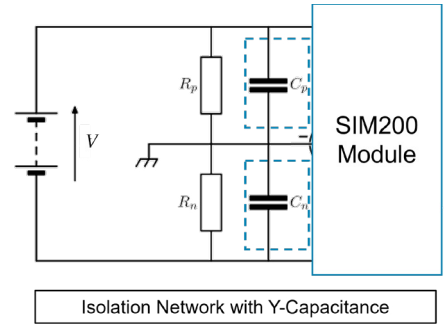

Presence of Y-capacitors

Y-capacitors should be connected directly to the IT power lines. Connecting them on the SIM200 board instead would impair the ability of the monitor to detect disconnection from the monitored IT power lines.

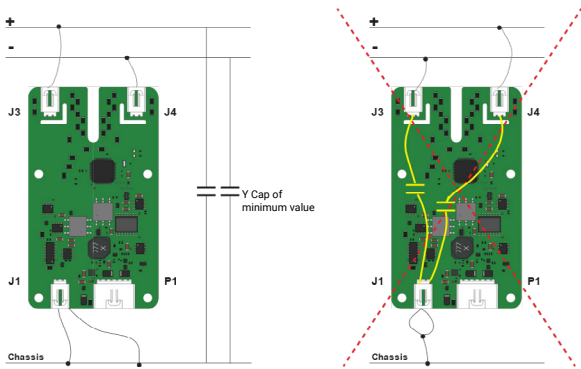

Connection to Isolated Terra (IT) Power System and Chassis

The SIM200 should connect through J1 at two separate chassis points. The SIM200 relies on this type of connection to detect proper connection to the chassis.

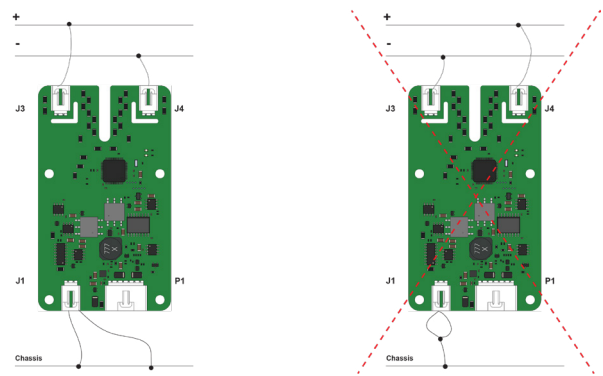

PWM Fault Output

SIM200 includes a dedicated Pulse-Width-Modulation output for reporting of system state, including Warnings and Faults.

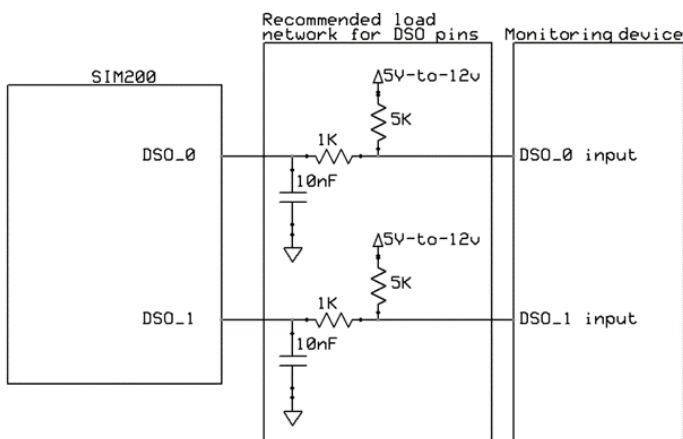

DSO_1 PWM	DSO_0 State	Description
20%	0	Isolation Status Unknown: unable to determine isolation resistance (expected for up to response times during isolation transitions), SIM is disabled, or a hardware error is detected (e.g. missing connection)
40%	0	Electrical isolation below fault threshold (iso_fault_thr)
60%	0	Electrical isolation below warning threshold (iso_warning_thr) and above fault threshold
80%	0	Electrical isolation status OK – above Warning Threshold
Any	1	Isolation Status Unknown - SIM Internal Error

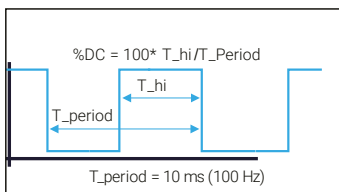

PWM is falling edge referenced

SIM200™

Mounting Pattern and Connectors

Dimensions in mm

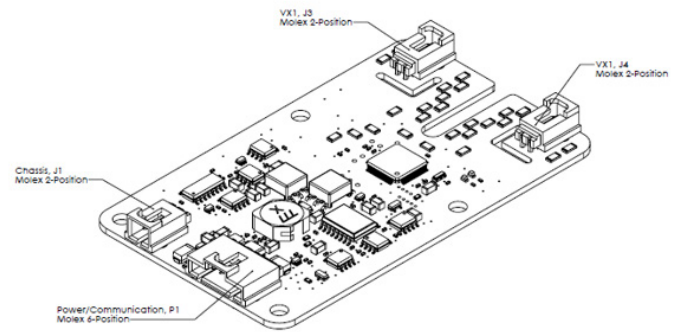
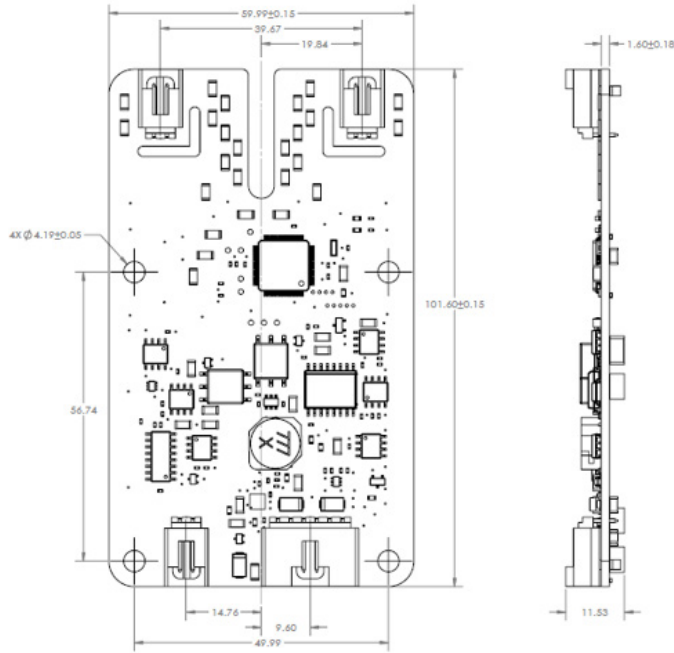

Connector ID	Manufacturer	Part Number	Mating Connector PN	Mating Connector W/TPA PN
P1	Molex	705510040	50579406	50579706
J1, J3, J4	Molex	705510036	50579402	50579702

Handling and Installation Instructions

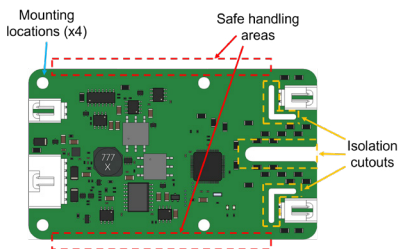

Mounting Specifications

- Electrical connections made with three 2-pin Molex connectors and one 6-pin Molex connector.
- Electrical harness connections validated up to 10 disconnect-reconnect cycles.
- Mounting through hole diameter: 4.19 ± 0.05 mm.
- All mechanical validation with SIM200 was completed using 18-8 Stainless Steel Screws with 8-32 thread size.
- Mounting torque shall not exceed 35 N cm.
- Nylon washers may be used between screws and PCB for improved isolation between application chassis and board but are not required for device function.
- For applications with vibration requirements, thread lock solution may be used on screws to prevent screws backing out over device life.

Installation Considerations

- SIM200 devices are designed to operate in high voltage applications that may present a shock hazard to users.
 - High voltage applications shall be unpowered before accessing SIM200 devices.
 - Access to SIM200 devices shall be restricted to trained operators only.
- SIM200 devices are ESD (electrostatic discharge) vulnerable devices. Operators shall wear ESD bracelets when interfacing with SIM200 devices.
- SIM200 devices contain exposed surface mounted components.
 - An operator's hands and tools shall avoid interfacing with surface mounted components and only touch safe handling areas (see diagram) on edges of SIM200 PCBs.
- SIM200 devices include intentional isolation cutouts (see diagram) to meet creepage and clearance requirements.
 - Materials with dielectric strength less than air (3 MV/m) shall not pass through isolation cutouts.

SIM200™

Connector Pinout

For reference, pinout information is also printed on the backside of the PCB:

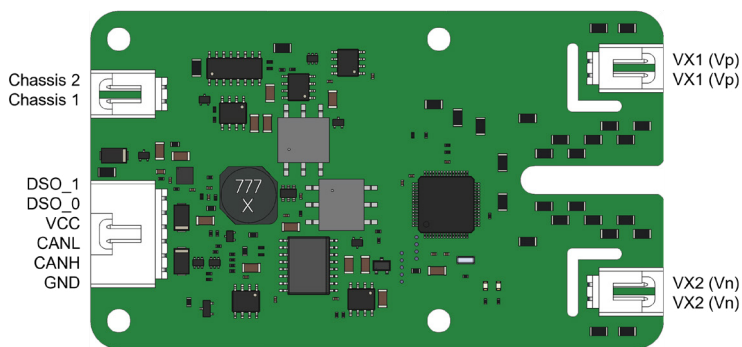
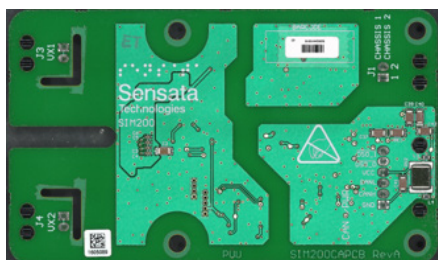

Chassis 1	One of two independent connections to chassis
Chassis 2	One of two independent connections to chassis
VX1 (Vp)	HV supply +
VX2 (Vn)	HV supply -
DSO_1	PWM output (must be pulled-up to 5-12 V with 5 k resistor)
DSO_0	Digital output (must be pulled-up to 5-12 V with 5 k resistor)
VCC	Supply voltage
CANL	CAN low pin
CANH	CAN high pin
GND	GND

LED Indications

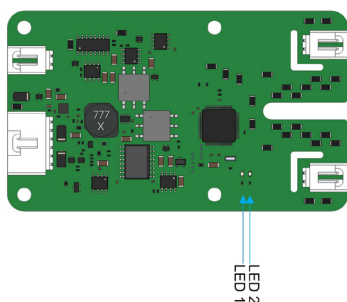

Sequence 1		Sequence 2		Sequence 3		Sequence 4		SIM200 operating state
LED 1	LED 2	LED 1	LED 2	LED 1	LED 2	LED 1	LED 2	
ON	OFF	OFF	ON	ON	OFF	OFF	ON	Normal operation (period = 2 seconds)
ON	ON	ON	OFF	OFF	OFF	OFF	ON	

Creepage and Clearance

HV+ to HV-	Basic insulation
Isolation between CAN bus, DSO, LV PWR and HV Connections	5 kV

*Note - The SIM200 is not an isolated measuring device. Between HV+ and HV- and chassis there exists a resistance equal to the input variance of the specific variant.

The minimum creepage/clearance distance is 3 mm (nonhomogeneous) between the HV and LV sections of the board.

SIM200™

Ordering Options

- The following ordering options are available for SIM200-<XYZ> where:
 X = CAN communication Speed (A = 500 kbps, B = 250 kbps)
 Y = Voltage Range (See Below Table)
 Z = CAN Resistor Termination (A = 120 Ω Termination, B = No Termination)
- Note the following definitions:
 Max Operational Voltage: The maximum voltage condition under which the SIM200 can monitor the system correctly – this should be the absolute highest voltage under which SIM200 is required to correctly monitor system insulation.
 Max Nominal System Voltage: The maximum permissible nominal system voltage for which a variant is suitable, given the requirements for an Insulation Monitor in IEC/EN 61557-8.
 Application Voltage Range: The range of nominal system voltages for which a given variant is capable to reliably resolve Insulation Faults of 100 Ω/V.
- Example: SIM200 is monitoring a DC charger with output up to 1000 V under typical conditions. According to IEC/EN 61557-8, the SIM200 must be operational at voltages 115% of the nominal (1000 V) = 1150 V.

Variant	Max Nominal System Voltage	Max Operational Voltage	Minimum Total Y-Capacitance (µF)	Application Voltage Range	Max Voltage Withstand Vx1 or Vx2 to CAN	Max Voltage Withstand Vx1 to Vx2	Max Voltage Withstand Vx1 or Vx2 to Vch
SIM200-xNx	1363	1568	0.2	1000-1363 V	5 kV	5 kV	2.5 kV
SIM200-xKx	1000	1150	0.2	600-1000 V	5 kV	5 kV	2.5 kV
SIM200-xPx	510	582	0.9	300-510 V	5 kV	3 kV	1.5 kV
SIM200-xQx	140	161	2	60-140 V	5 kV	1 kV	0.5 kV
SIM200-xKxX	Reference SIM200-xKx specifications for hardware and performance details. Fault threshold is configurable and therefore this part is not UL compliant or covered by CE certification. See below notes on configuration.						

Configuration

SIM200 features a “Setup Mode” where the CAN 2.0B interface can be used to configure the IMD. CAN speed, CAN ID, system max voltage, and the isolation warning threshold can all be configured from the default values if needed for the application. See CAN protocol “Setup Mode” and “Commands” for details on modifying the “Configuration Parameters”.

Thresholds

Fault (100 Ω/V) and warning (500 Ω/V default) thresholds are calculated using the configured system max voltage. If a higher voltage than the configured system max voltage is seen by the SIM200, the thresholds will be raised accordingly until the device is reset (via command or power cycle).

When configuring warning threshold, ensure that any applicable safety standards are met by referring to the accuracies defined on the data-sheet. Fault threshold is locked* to comply with UL2231 recognition requirements.

*For SIM200-xKxX, fault threshold is also configurable as described in the CAN protocol. Ensure that any applicable safety standards are met. Note that higher amounts of instability in isolation state output can be expected at very low thresholds in addition to the lesser accuracy specified in the datasheet. SIM200 variants were validated to calculate fault thresholds within their respective application voltage ranges with 100 Ω/V fault threshold (e.g., 60 to 100 KΩ on SIM200-xKx) per UL2231. For fault resistances that are below this range, it is recommended to run application representative validation tests to ensure proper functionality.

Agency Approvals and Certifications



Datasheets provided by Sensata Technologies, Inc., its subsidiaries and/or affiliates (“Sensata”) are solely intended to assist third parties (“Buyers”) who are developing systems that incorporate Sensata products (also referred to herein as “components”). Buyer understands and agrees that Buyer remains responsible for using its independent analysis, valuation, and judgment in designing Buyer’s systems and products. Sensata datasheets have been created using standard laboratory conditions and engineering practices. Sensata has not conducted any testing other than that specifically described in the published documentation for a particular datasheet. Sensata may make corrections, enhancements, improvements, and other changes to its datasheets or components without notice. Buyers are authorized to use Sensata datasheets with the Sensata component(s) identified in each particular datasheet. HOWEVER, NO OTHER LICENSE, EXPRESS OR IMPLIED, BY ESTOPPEL OR OTHERWISE TO ANY OTHER SENSATA INTELLECTUAL PROPERTY RIGHT, AND NO LICENSE TO ANY THIRD PARTY TECHNOLOGY OR INTELLECTUAL PROPERTY RIGHT, IS GRANTED HEREIN. SENSATA DATASHEETS ARE PROVIDED “AS IS”. SENSATA MAKES NO WARRANTIES OR REPRESENTATIONS WITH REGARD TO THE DATASHEETS OR USE OF THE DATASHEETS, EXPRESS, IMPLIED, OR STATUTORY, INCLUDING ACCURACY OR COMPLETENESS. SENSATA DISCLAIMS ANY WARRANTY OF TITLE AND ANY IMPLIED WARRANTIES OF MERCHANTABILITY, FITNESS FOR A PARTICULAR PURPOSE, QUIET ENJOYMENT, QUIET POSSESSION, AND NON-INFRINGEMENT OF ANY THIRD PARTY INTELLECTUAL PROPERTY RIGHTS WITH REGARD TO SENSATA DATASHEETS OR USE THEREOF. All products are sold subject to Sensata’s terms and conditions of sale supplied at www.sensata.com. SENSATA ASSUMES NO LIABILITY FOR APPLICATIONS ASSISTANCE OR THE DESIGN OF BUYERS’ PRODUCTS. BUYER ACKNOWLEDGES AND AGREES THAT IT IS SOLELY RESPONSIBLE FOR COMPLIANCE WITH ALL LEGAL, REGULATORY, AND SAFETY-RELATED REQUIREMENTS CONCERNING ITS PRODUCTS, AND ANY USE OF SENSATA COMPONENTS IN ITS APPLICATIONS, NOTWITHSTANDING ANY APPLICATIONS-RELATED INFORMATION OR SUPPORT THAT MAY BE PROVIDED BY SENSATA. Mailing Address: Sensata Technologies, Inc., 529 Pleasant Street, Attleboro, MA 02703, USA

Regional head offices:
 United States of America
 Sensata Technologies
 Attleboro, MA
 Phone: 508-236-3800
 E-mail: support@sensata.com

Netherlands
 Sensata Technologies
 Holland B.V.
 Hengelo
 Phone: +31 74 357 8000
 E-mail: support@sensata.com

China
 Sensata Technologies China
 Co., Ltd.
 Shanghai
 Phone: +8621 2306 1500
 E-mail: support@sensata.com